

PDDC Perforated Circular Displacement Diffuser



Perforated circular displacement diffuser is a low velocity diffuser for floor installation. PDDC consists of a detachable front panel and removable inner structure. The fixed flow equalization casing allows the air uniformly distributed.

Materials

Perforated aluminum sheet frame.
Perforated galvanized steel sheet frame.
Perforated stainless steel sheet frame.

Surface Finish

Baked white powder coat as standard.

Dimension

Comply with requirement.

Function

Supply air is brought into the space through the front panel of the PDDC. Normally the supply air temperature is set lower than the room temperature; therefore, the incoming air moves down to the floor level and gradually pervades the occupied zone. The flow pattern is circular. Workstation can be located close to the PDDC.

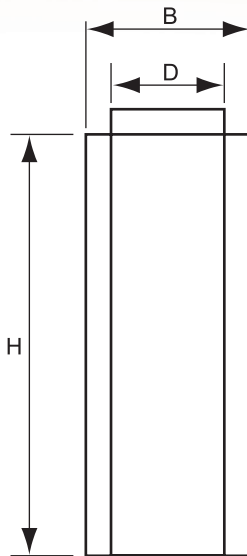

PDDC Construction Illustrations

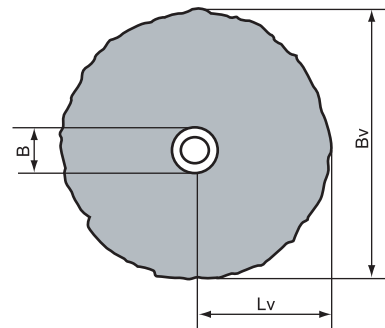
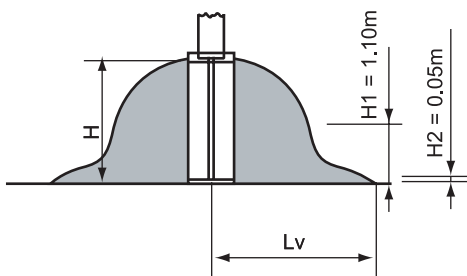

PDDC Order Code *Unit : mm*

Model	Materials	D	H
PDDC	T	320	1800

PDDC Perforated Circular Displacement Diffuser

Quick Selection Guide

D (mm)	Q (CMH)	Δ Pt (mmAq)	B x H (mm x mm)	H1 = 1.10m				H2 = 0.05m			
				v = 0.2 m/s		v = 0.35 m/s		v = 0.2 m/s		v = 0.35 m/s	
				Lv (m)	Bv (m)	Lv (m)	Bv (m)	Lv (m)	Bv (m)	Lv (m)	Bv (m)
200	450	1.22	270 x 1000	-	-	+	+	0.5	1.0	+	+
	560	1.84		-	-	+	+	0.7	1.4	+	+
	660	2.55		-	-	+	+	1.9	3.6	0.3	0.6
250	690	1.22	320 x 1200	-	-	+	+	1.5	3.0	+	+
	840	1.73		0.4	0.8	+	+	1.7	3.4	+	+
	1000	2.45		0.4	0.8	+	+	1.9	3.8	0.4	0.8
320	1110	1.43	400 x 1300	0.6	1.2	+	+	2.2	4.4	+	+
	1310	2.04		0.7	1.4	+	+	2.5	5.0	0.5	1.0
	1560	2.86		1.0	2.0	0.4	0.8	3.0	6.0	0.6	1.2
400	1840	1.33	500 x 1800	1.2	2.4	0.5	1.0	3.1	6.2	0.6	1.2
	2240	1.73		1.9	3.8	0.8	1.6	4.1	7.2	0.9	1.8
	2650	2.35		2.6	5.2	0.9	1.8	6.0	12.0	1.1	2.2
500	2830	1.33	630 x 1900	2.3	4.6	0.4	0.8	4.1	8.2	0.4	0.8
	3420	1.93		2.8	5.6	0.5	1.0	4.6	9.2	0.6	1.2
	4050	2.55		3.3	6.6	0.6	1.2	5.3	10.6	1.0	2.0
600	3740	1.22	800 x 2000	3.0	6.0	0.6	1.2	5.0	10.0	0.9	1.8
	4750	1.94		3.8	7.6	0.8	1.6	6.1	12.2	1.2	2.4
	5760	2.86		5.2	10.4	1.3	2.6	6.9	13.8	2.0	4.0

- = V < 0.2 m/s + = V < 0.35 Nearzone temperature difference = -3°C

Sound Power Level In Octave Bands

D (mm)	Q (CMH)	Δ Pt (mmAq)	Frequency (Hz)								SWL
			63	125	250	500	1000	2000	4000	8000	db (A)
200	470	1.33	35	31	28	31	25	-	-	-	25
	560	1.84	41	31	30	34	30	19	-	22	31
	670	2.65	44	32	34	39	37	25	18	22	35
	780	6.67	45	34	38	41	41	35	23	23	41
250	690	1.22	38	24	25	30	-	-	-	20	23
	840	1.73	44	30	32	36	25	-	18	22	29
	980	2.35	45	35	35	39	34	25	21	24	34
	1200	3.47	45	39	40	42	44	34	26	28	41
320	1100	1.53	33	28	32	25	24	-	-	-	26
	1300	2.04	40	31	34	33	29	18	-	20	30
	1560	2.86	41	35	38	38	35	25	-	21	34
	1850	3.88	43	38	41	41	43	33	22	21	42
400	1830	1.33	40	33	25	25	24	22	19	21	23
	2200	1.73	53	34	33	34	28	19	21	25	28
	2600	2.35	53	34	37	39	36	25	23	27	34
	3000	3.06	53	37	40	42	42	31	25	27	41
500	3450	1.94	46	32	35	33	29	19	18	24	31
	4000	2.45	50	34	37	35	34	24	19	25	35
	4500	3.16	54	36	41	39	39	28	20	32	38
	5000	3.77	57	38	42	42	44	31	21	33	41
600	4700	1.94	54	32	31	30	25	-	-	31	31
	5500	2.55	57	34	35	32	30	-	-	35	33
	6300	3.37	60	36	38	35	36	22	18	38	38
	7000	4.28	61	38	40	37	39	23	19	41	39

- = Sound power level < 17 dB