

SLR-LP Rectangular Silencer

■ Description

ASLI Rectangular Silencer (SLR-LP) is designed for intake or exhaust fans of high air velocity and low pressure drop. Large equipment usually requires a substantial amount of airflow but untreated fan areas can create, and even spread, noise unnecessarily. The acoustic material, fibre glass in the baffles reduces the noise transmitted through the duct work. Perforated metal sheet protects the fibre glass from being eroded by air flow. The baffles are aerodynamically shaped to minimize turbulent flow and pressure drop.

■ Material

- Outer casing: 1.0mm thickness galvanized steel.
- Baffle: 0.7mm thickness perforated galvanized steel.
- Acoustical material: fiber glass.

■ Surface Finish

- Mill galvanized.

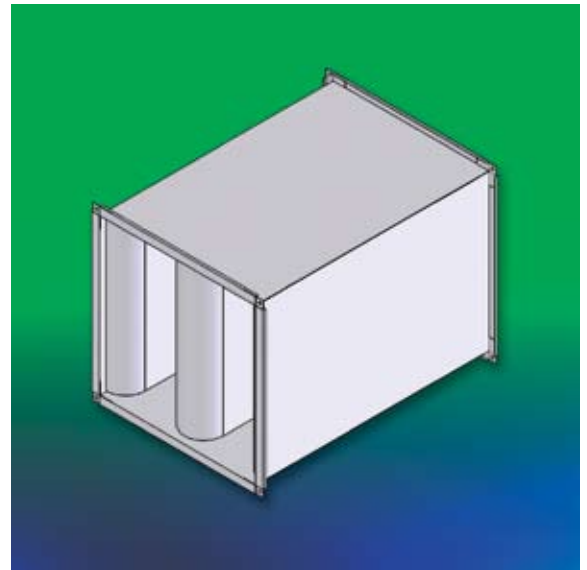

■ Construction Illustration

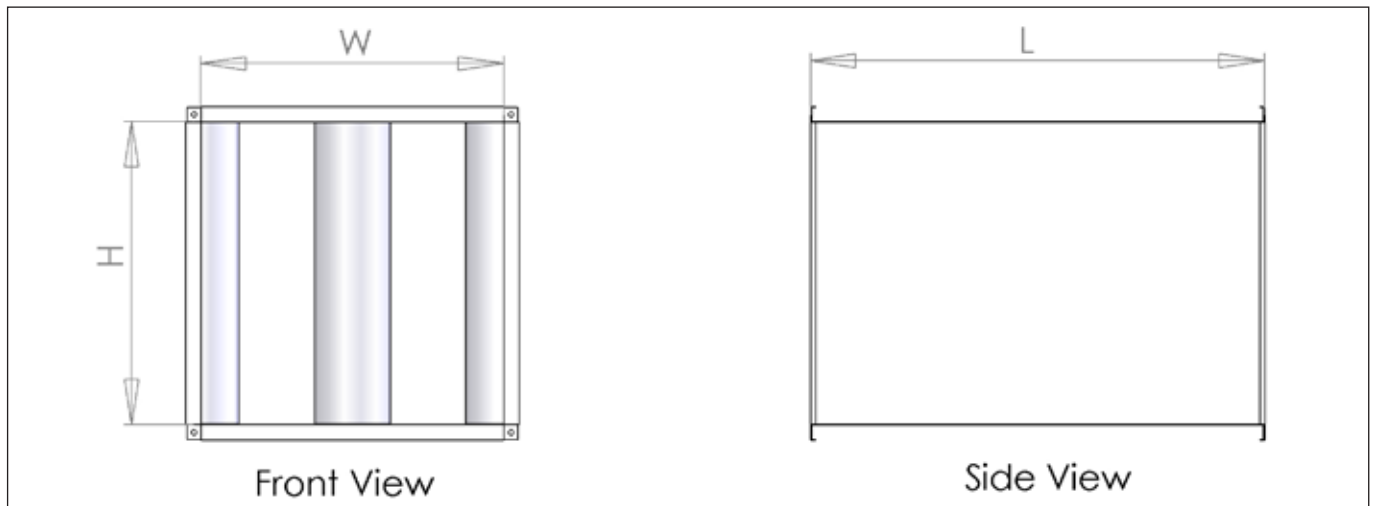

■ SLR-LP Table 1: Insertion Loss

Length (mm)	Frequency (Hz)	63	125	250	500	1000	2000	4000	8000
	Face Velocity (m/s)	Insertion Loss (dB)							
900	-10	1	5	7	16	29	25	13	11
	0	2	3	8	16	20	21	18	12
	10	2	2	6	12	18	21	18	14
1500	-10	2	12	15	33	36	38	18	15
	0	3	9	15	30	38	37	25	15
	10	3	7	12	22	33	35	24	17
2100	-10	3	14	20	43	44	50	20	13
	0	4	11	23	41	49	44	28	14
	10	4	11	16	30	44	42	28	18
3000	-10	9	21	24	53	60	60	33	22
	0	7	16	24	46	60	56	40	22
	10	9	17	17	36	62	58	40	26

- Positive face velocity indicates forward flow while negative face velocity indicates reverse flow.
- Forward flow occurs when the air flow is in the same direction as the noise transmitted.
- Reverse flow occurs when the air flow is opposite the noise transmitted direction.
- Zero face velocity indicates static insertion loss; the rest are dynamic insertion losses.

SLR-LP Rectangular Silencer

■ SLR-LP Table 2: Air Generated Sound Power Level

Frequency (Hz)	63	125	250	500	1000	2000	4000	8000
Face Velocity (m/s)	Air Flow Generated Sound Power Level (dB)							
-10	55	54	58	55	61	63	55	48
-5	38	42	46	40	44	43	39	28
5	40	37	36	38	34	37	31	33
10	54	53	51	49	47	56	49	46

• The above performance data is generated from 0.36m² face area silencer. Please use the correct factor at table 3 for other face area silencers.

■ SLR-LP Table 3: Correction Factor for Air Generated Sound Power Level

Face Area (m ²)	0.09	0.19	0.36	0.74	1.49	2.97	5.95	11.90
Correction Factor (dB)	-6	-3	0	+3	+6	+9	+12	+15

■ SLR-LP Table 4: Pressure Drop

Length (mm)	Face Velocity (m/s)					
	2.5	5.0	7.5	10.0	12.5	15.0
	Dynamic Pressure Drop (Pa)					
900	5	17	36	63	99	143
1500	5	19	43	75	118	169
2100	7	29	63	114	176	254
3000	7	29	68	118	186	268

• Shaded regions in table 4 represent a design condition that may have negative consequences for acoustically sensitive applications.

■ SLR-LP Order Code

Model	Width, W (mm)	Height, H (mm)	Length, L (mm)
SLR-LP	600	600	900

Example: SLR-LP W600XH600XL900mm