

VVD VAV Diffusers

Introduction

ASLI VAV diffusers, VVD are variable air volume diffuser for supply air in variable air volume system. In many conventional HVAC systems, multiple work spaces are controlled by a single thermostat. Complaints from occupants who are too hot or too cold are common as the occupants attempt to adjust the thermostat to their level of comfort.

VVD enhances conventional system design by adding the element of personal control. A room thermostat provides constant feedback to the VVD, enabling precise control of the space temperature by controlling the supply air volume into the room.

The actuator mechanism features high torque, low voltage motor which offers immediate response, superior to the sluggish response and delayed action common to thermally activated expansion device.

ASLI VAV Diffuser Vs Conventional VAV System

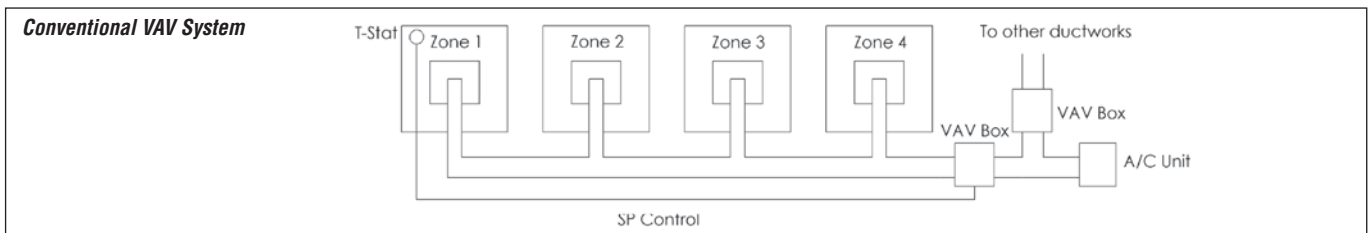

- Large zone controlled by one thermostat.
- Zones with varying load characteristics.
- Individual zone control is not available.
- Zone with thermostat determines supply air volume to all zones.
- Overcooling or overheating may occur in zones without thermostat.

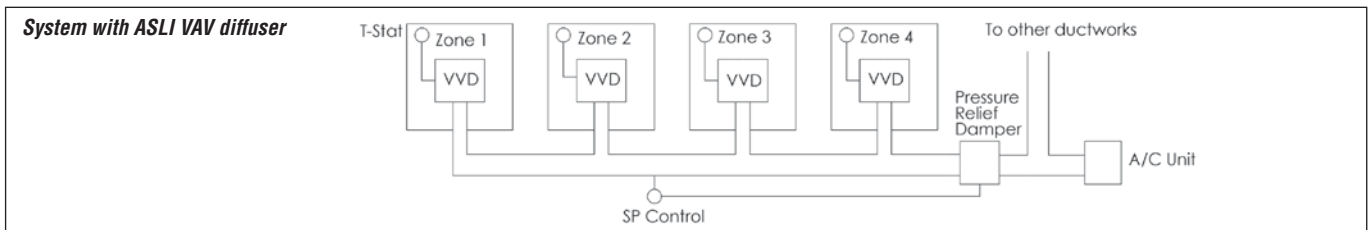

- Each zone is controlled by one thermostat
- Individual zone control is available
- Modular design allows relocation as needs change
- Pressure relief damper releases the pressure in the main duct when pressure builds up.

Operation

ASLI VAV diffusers, VVD maintain space temperature by varying the air volume delivered to the space. The amount of air delivered will depend on the room temperature and temperature set point. As the air volume is decreased by the control disc, the air velocity increased, thereby maintaining the longest throw and best entrainment. This insures superior air distribution at all damper positions. Supply air is discharged horizontally in a uniform 4-way pattern while the variable geometry design ensures that adequate room air movement is maintained throughout the full range of volume variation.

Individual comfort control

Comfort level of each zone is controlled with their own thermostat. In addition to providing individual comfort control, having individual sensors in each zone will allow each VAV diffuser to react to variations in the zone. For example, if there is no occupant (no heat load) in the zone, the diffuser will sense the lower zone temperature and adjust the control disc to reduce the supply air to the zone. Having individual zone control and temperature sensing allows the control disc to react faster to load changes in the zone eliminating over-and under-cooling of the zone.

Energy Savings

When the duct static pressure increase as VAV diffuser closes the control disc, the by-pass damper, volume control damper or variable speed drive of fan (depending on the system) will regulate the static pressure in the main duct. This is to ensure there is no excess static pressure in the main duct. Excess static pressure in the main duct is literally equivalent to excess energy used. When the return air temperature decreased (due to by-pass supply air), the control valve will close to reduce the chill water supply into the air handling unit. As the chill water supply pressure increased when the control valves close, the chill water by-pass valve will open to by-pass the chill water back to the chillers. Energy savings can be achieved without compromising the occupants comfort level by a series of operations in the air conditioning system.

Applications

ASLI VAV diffusers can be used to address challenging areas such as areas with varying load requirements like conference room and individual offices. In a system with more than 30% of VAV diffuser, pressure control will need to be used.

VVD VAV Diffusers

Description

ASLI VAV diffusers, VVD feature an architecturally pleasing faceplate design and high performance inner cone. VAV diffusers maintain space temperature by varying the air volume delivered to the space when heat load and space condition changed.

Materials

- Frame: 0.7mm galvanized steel.
- Face Plate: 0.7mm galvanized steel.
- Control Disc: 0.5mm galvanized steel.

Surface Finish

- White powder coated as standard.

Standard Construction Features

- High torque gear motor for fast response, long life and reliable operation.
- Steel back pan, faceplate and inner cone for strength and durability.
- Engineered faceplate design for enhance air performance and low noise level.
- Faceplate is removable for maintenance purposes.



VVD Construction Illustrations

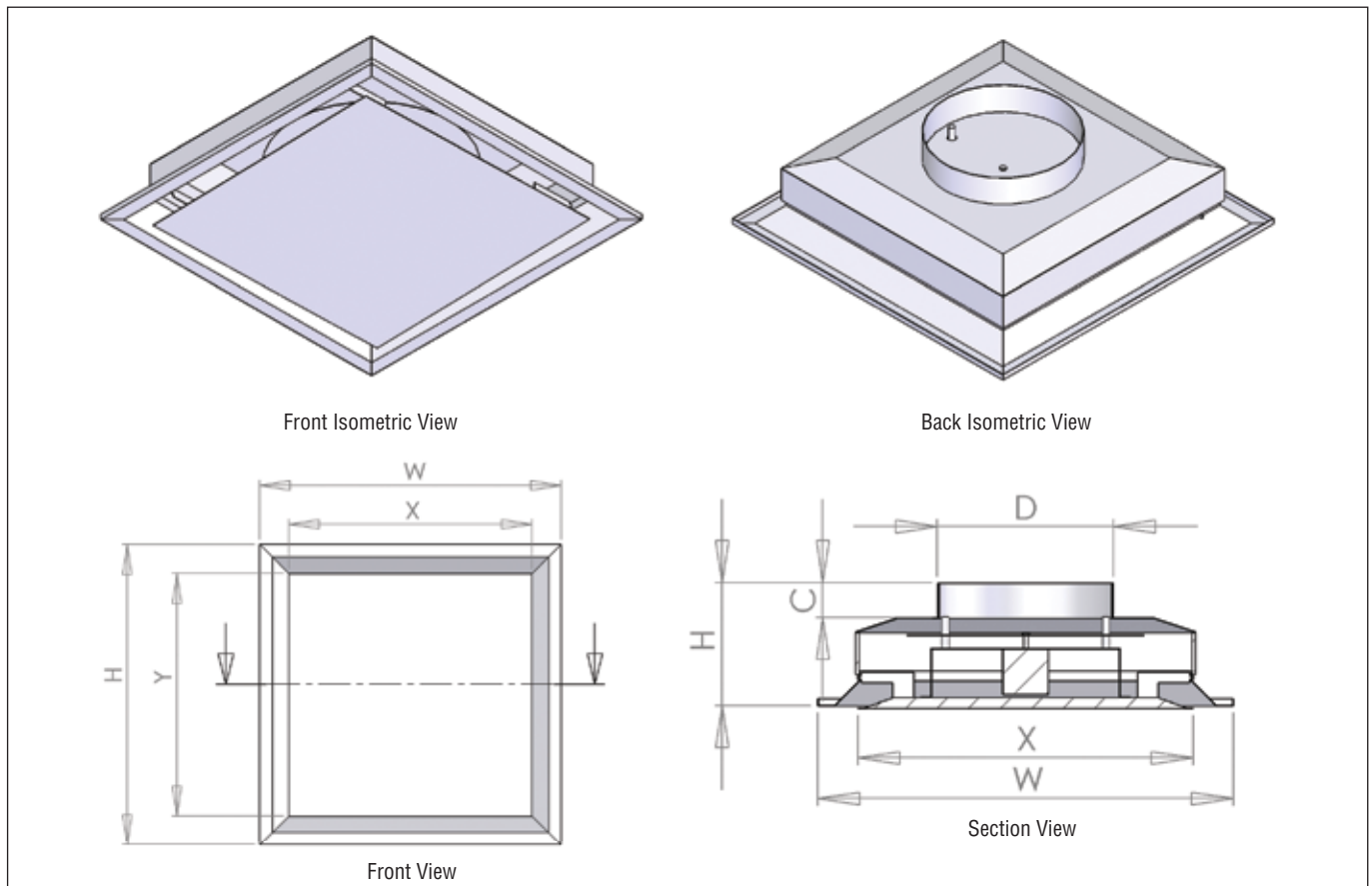

VVD Physical Dimension Unit:mm

W	H	X	Y	D	C	H
595 / 603	595 / 603	480	480	150 - 300	50	170

VVD VAV Diffusers

■ VVD Illustrations

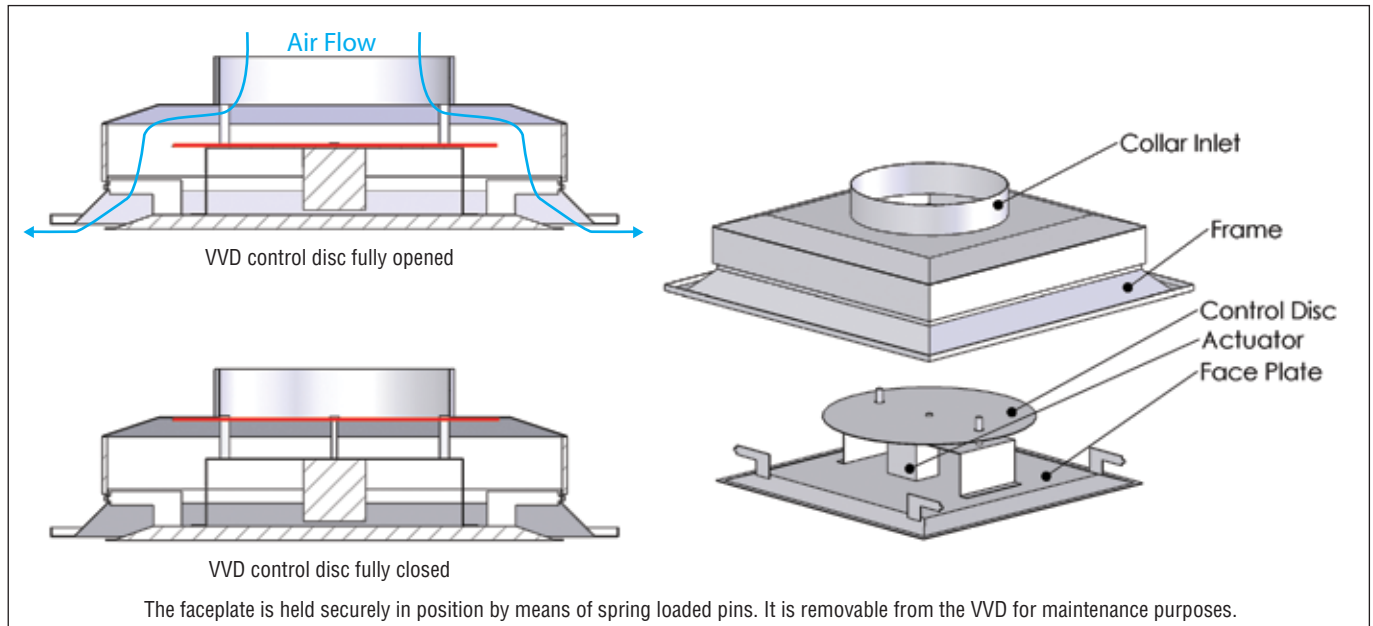

■ VVD Performance Data

Neck Size (mm)	Neck Vel.(m/s)	2.0	2.5	3.0	3.5	4.0	4.5	5.0
150	Pv (Pa)	2	4	5	8	10	12	15
	Ps (Pa)	11	18	25	35	45	58	71
	Pt (Pa)	14	22	31	42	55	70	86
	CMH	121	150	181	210	240	271	300
	NC	-	-	20	25	29	33	36
	Throw (m)	0.3 - 0.9	0.6 - 0.9	0.6 - 0.9	0.6 - 1.2	0.6 - 1.2	0.9 - 1.2	0.9 - 1.2
200	Ps (Pa)	9	13	19	26	34	43	54
	Pt (Pa)	11	17	25	34	44	56	69
	CMH	214	268	320	373	427	480	534
	NC	-	20	25	29	33	37	40
	Throw (m)	0.9 - 2.1	1.2 - 2.1	1.5 - 2.4	1.8 - 2.7	2.1 - 2.7	2.1 - 3.0	2.1 - 3.4
250	Ps (Pa)	8	12	17	24	31	39	48
	Pt (Pa)	10	16	23	31	41	52	64
	CMH	334	418	500	584	667	751	834
	NC	-	24	27	32	36	39	42
	Throw (m)	1.5 - 2.7	2.1 - 3.4	2.4 - 3.7	2.7 - 3.7	2.7 - 4.0	3.0 - 4.3	3.4 - 4.6
300	Ps (Pa)	11	18	26	35	46	58	71
	Pt (Pa)	14	22	31	43	55	70	87
	CMH	427	534	641	748	854	962	1068
	NC	23	28	33	38	41	45	48
	Throw (m)	2.4 - 3.4	2.7 - 4.0	3.0 - 4.3	3.4 - 4.6	3.4 - 4.9	3.7 - 5.2	4.0 - 5.5
350	Ps (Pa)	14	22	32	43	56	71	88
	Pt (Pa)	17	26	37	51	66	84	103
	CMH	655	819	981	1144	1308	1472	1636
	NC	26	32	37	41	44	47	50
	Throw (m)	2.7 - 4.0	3.0 - 4.6	3.4 - 4.9	3.7 - 5.2	4.0 - 5.8	4.3 - 6.1	4.6 - 6.4

- Pv = Velocity Pressure, Ps = Static Pressure, Pt = Total Pressure.
- Performance data is obtained with the control disc in the full open position.
- Throw is based on terminal velocities of 0.5 – 0.25 m/s.
- NC value is based on a room absorption of 10dB, re 10⁻¹² watts.
- Dash (-) in space indicates NC value less than 20.

VVD VAV Diffusers System Designs

System Balancing

During commissioning, balancing dampers are used to set the desired flow through each branch duct/diffuser. Typically, balancing dampers near the fan are adjusted to provide a high resistance to the airflow, in order to reduce excess duct static pressure. Conversely, balancing dampers far from the fan are adjusted nearly open to provide low resistance to airflow, where duct static pressure is low. Please do not rely upon VVD to take the place of a required balancing damper.

Balancing the VVD system is simple. First, drive open all VVD diffusers by adjusting the thermostat set point to the lowest temperature possible. If using bypass pressure control, close all bypass terminal dampers before balancing. If using volume control damper pressure control, open all volume control dampers. Next, select a diffuser that requires highest pressure to satisfy its design flow and measure its air flow rate of this diffuser. If it is too high, reduce the system duct static pressure. If it is too low, increase the system duct static pressure. The system is now effectively balanced since remaining diffusers require less pressure will drive as far open as needed to satisfy individual flow rates. If the system is constant volume, a bypass pressure control damper is required. The bypass damper should be sized to bypass up to 70% of the system air volume with a maximum face velocity of 5m/s. This assumes a minimum of 30% air flow for the diffusers.

Static Pressure Control

Static pressure control should be taken care of when using ASLI VVD diffusers. Static pressure greater than the recommended pressure may result in excessive air flow and increased noise level. The duct static pressure will increase as the VVD begin to close towards minimum flow with room load variations. Therefore pressure control is a must in systems where 30% or more of the total fan air flow rate is being delivered through VVD diffusers.

1. Volume Control Damper (Figure 1, 2)

Volume control damper is installed at upstream of VVD diffusers. The volume control damper regulates duct static pressure based on a pressure sensor set point located near the end of the longest duct run.

2. By-Pass Damper (Figure 3)

By-pass damper is installed at upstream of VVD diffusers. The by-pass damper regulates duct static pressure based on a pressure sensor set point located near the end of the longest duct run. The by-pass damper can discharge the air flow directly to the ceiling plenum or be ducted to the fan return.

3. Fan Speed Control (Figure 4)

Fan speed control can be achieved by using a variable speed drive to regulate the fan air volume based on duct static pressure.

Figure 1: Volume Control Damper

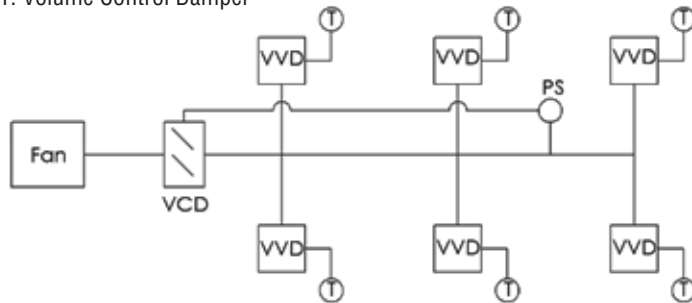

- One thermostat to one VVD.
- Main duct static pressure controlled by volume control damper.

Figure 2: Volume Control Damper

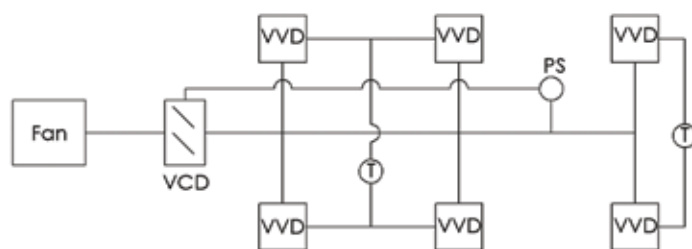

- One thermostat to multiple VVD.
- Main duct static pressure controlled by volume control damper.

VVD VAV Diffusers

Figure 3: By-Pass Damper

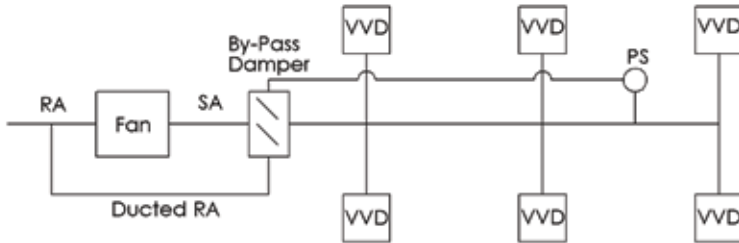

- Main duct static pressure controlled by by-pass damper

Figure 4: Fan Speed Control

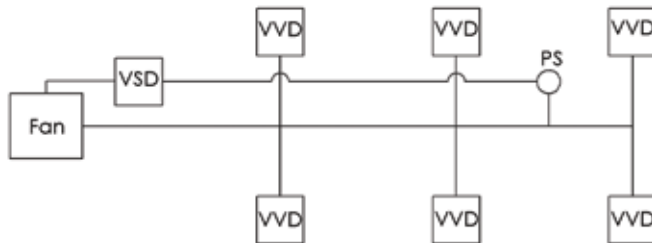

- Main duct static pressure controlled by variable speed drive of the fan

■ VVD Suggested Specification

VAV diffuser shall be ASLI, model VVD. Diffusers shall consist of a square frame, square faceplate and plenum box. Diffuser frame shall be 0.7mm galvanized steel. Face plate shall be 0.7mm galvanized steel. The exposed surface of the faceplate shall be smooth and flat. The faceplate shall be held securely in position by means of spring-loaded pins. The faceplate shall be completely removable from the diffuser to allow full access to inner components. The inner components shall consist of a control disc and a linear actuator. The linear actuator shall throttle the control disc to move up or down to control air volume by responding to the signal received from thermostat or BAS. Air volume control by using butterfly or flip damper at the inlet of the plenum box with rotary actuator is not acceptable. The diffuser shall be powder coated and furnished to architectural requirement.

■ VVD Order Code

Model	Base Size (W X H)	Inlet Diameter
VVD	595mmX595mm, 603mmX603mm	150, 200, 250, 300, 350mm

Example: VVD-603mmX603mm-250mm