

## T5NM 2-Point And 3-Point Control Actuator

### Description

ASLI is proud to offer the T5NM... series of damper actuators designed specifically applications into the HVAC market.

ASLI high quality damper actuators have been designed for use with air damper, butterfly valve, characterized ball valve and globe valve with the use of special adapter.

### Product Features

- Universal spindle clamp for easy direct mounting.
- Anti-rotation bracket provided for stability.
- Manual over ride by push button when required.
- Adjustable angle of rotation.
- Parallel connection up to when requested.
- Power saving at end stops.
- Customised version available, on request.
- High efficiency brushless dc motor.
- 2 speed in various application (high speed : 75s/low speed: 150s)
- Consistent and precise torque.
- Reliable, life cycle up to 100000 rotations.
- Attached with im cable connection.
- Small size and powerful.



### T5NM Model Selection Table

Torque	Running Time	Power Supply	Auxiliary Switches	Model/Type
5 Nm (T5Nm)	75s (high speed) 150s (low speed)	24 VAC/DC	No 1 x SPDT	ASLI-T5NM-D24.L1 ASLI-T5NM-D24.F2
		230 VAC	No 1 x SPDT	ASLI-T5NM-D230.L1 ASLI-T5NM-D230-F2.L1

### T5NM Actuator Dimensions Unit:mm

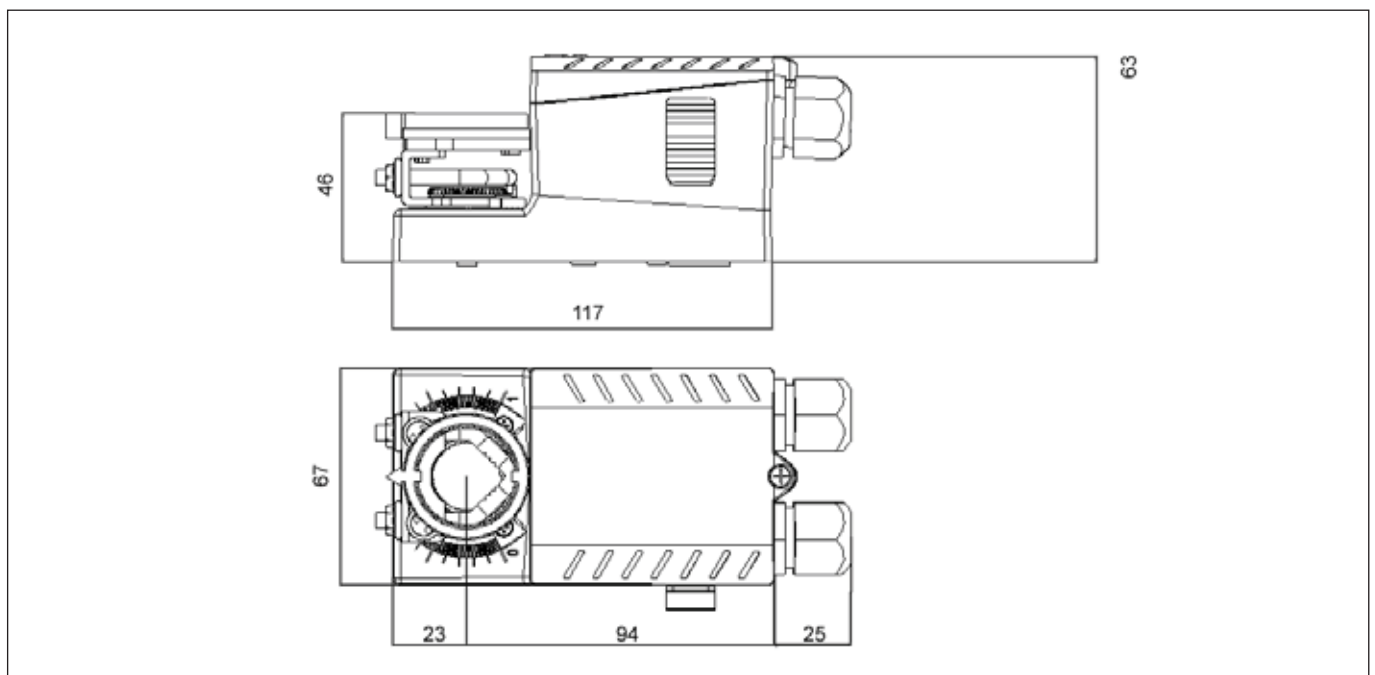

## T5NM 2-Point And 3-Point Control Actuator

### ■ M5NM Technical Specification

	ASLI-T5NM - D230	ASLI-T5NM - D24
Torque	5 Nm	5 Nm
Power supply	230 VAC ± 15%	24 VAC / VDC ± 15%
Frequency	50...60 Hz	50...60 Hz
Power consumption		
- Operating	1 W	1 W
- At the end stops	0.2 W	0.2 W
For wire sizing	6.5 VA	6.5 VA
Protection class	II (for 24 V and 220 V)	II (for 24 V and 220 V)
Control signals	2-point and 3-point	2-point and 3-point
Angle of rotation	90° (95° mechanical)	90° (95° mechanical)
Angle limiting	0°...90°	0°...90°
Weight	350g	350g
Life cycle	100,000 rotation	100,000 rotation
Sound level	Below 45 dB	Below 45 dB
IP protection	IP54 (with cable) IP42 (without cable)	IP54 (with cable) IP42 (without cable)
Ambient temperature	-30° ~ +50°C -20°C...50°C	-30°C ~ +50°C -20°C...50°C
Ambient humidity	≤ 95% rH(40°C)	rH ≤ 95%(40°C)
Inventory temperature	- 40°C ~ + 80°C	- 40°C ~ + 80°C
Maintenance	maintenance free	maintenance free
Certification	CE and ISO 9000	CE and ISO 9000
Covering material	ABS Project plastic	ABS Project plastic
Board material	Galvanised plate	Galvanised plate

### ■ T5NM Recommended Actuator Selection

Damper Neck Area (m <sup>2</sup> )	Recommended Actuator Torque (Nm)
0.75	4
1.5	8
3	16
4.5	24

### ■ T5NM Wiring Diagram

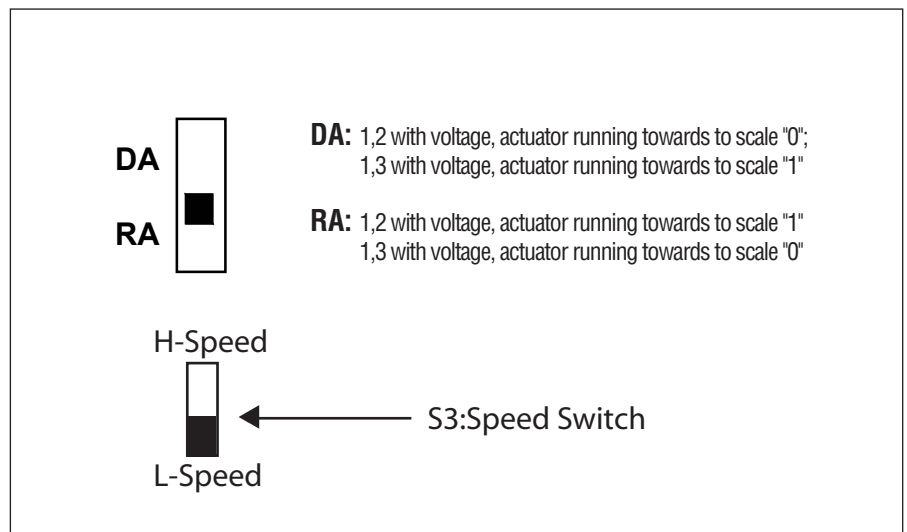
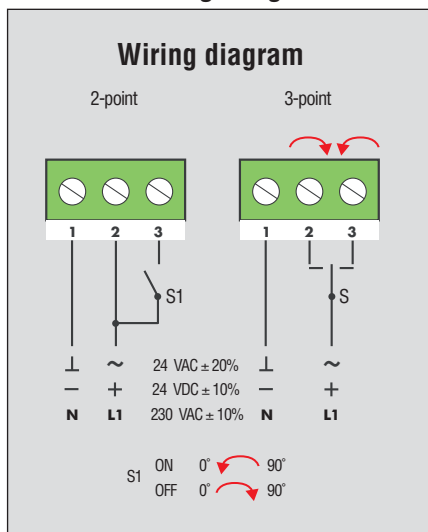

## T5NM 2-Point And 3-Point Control Actuator

### ■ T5NM Wiring Diagram

