

SPRD Single Blade Pressure Relief Damper

Description

ASLI SPRD single blade pressure relief dampers are designed to maintain certain amount of pressure in a pressurized zone (staircase, operation theatre, etc). The amount of pressure maintained in the pressurized zone is adjustable by the counterweight on the SPRD. The counter weight is hidden behind the blade for aesthetical purposes.

Materials

- Frame: Galvanized steel, 0.7mm thickness.
- Blade: Galvanized steel, 0.7mm thickness.

Features

- Single blade design.
- Excellent aesthetical appearance.
- Location of the counter weight is adjustable to control the inlet pressure.
- Counter weight is located behind the blade.
- Vertical (wall) installation.
- Damper must be installed with blade opens in up and down direction.

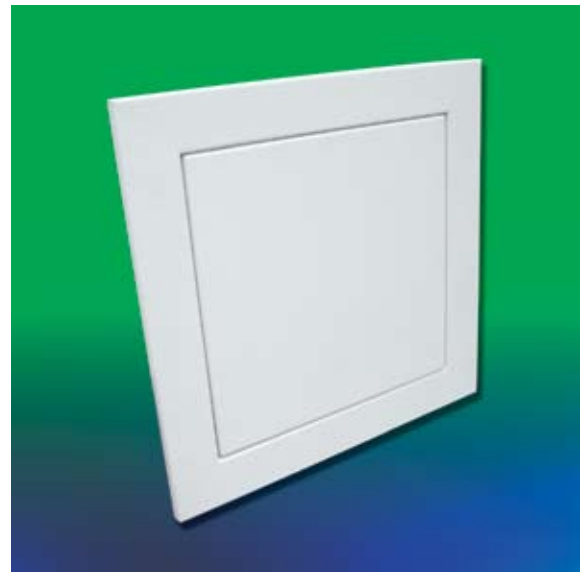

Standard Size (W XH)

- N250mmX250mm.
- Other sizes available upon request.

Construction Illustrations

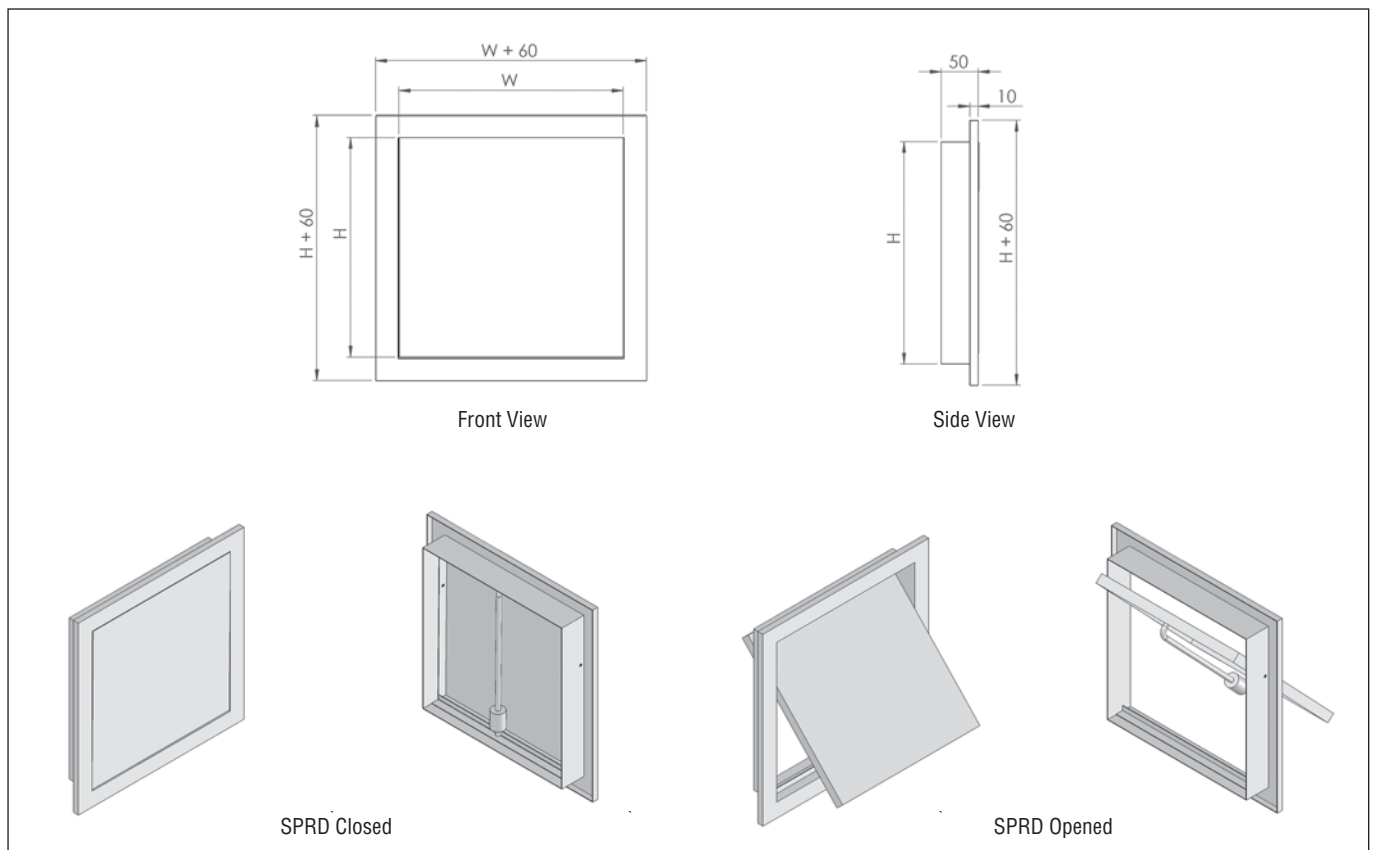

SPRD Single Blade Pressure Relief Damper

■ SPRD Pressure Setting

Counter weight of SPRD is located behind the blade; hence it is not visible from front view. The blade will gradually open when the pressure builds up. The location of the counter weight is adjustable by moving the counter weight up or down along the steel rod as shown in the diagram.

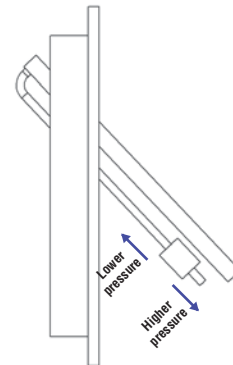

■ SPRD Air Flow Resistance Chart (N250mmX250mm)

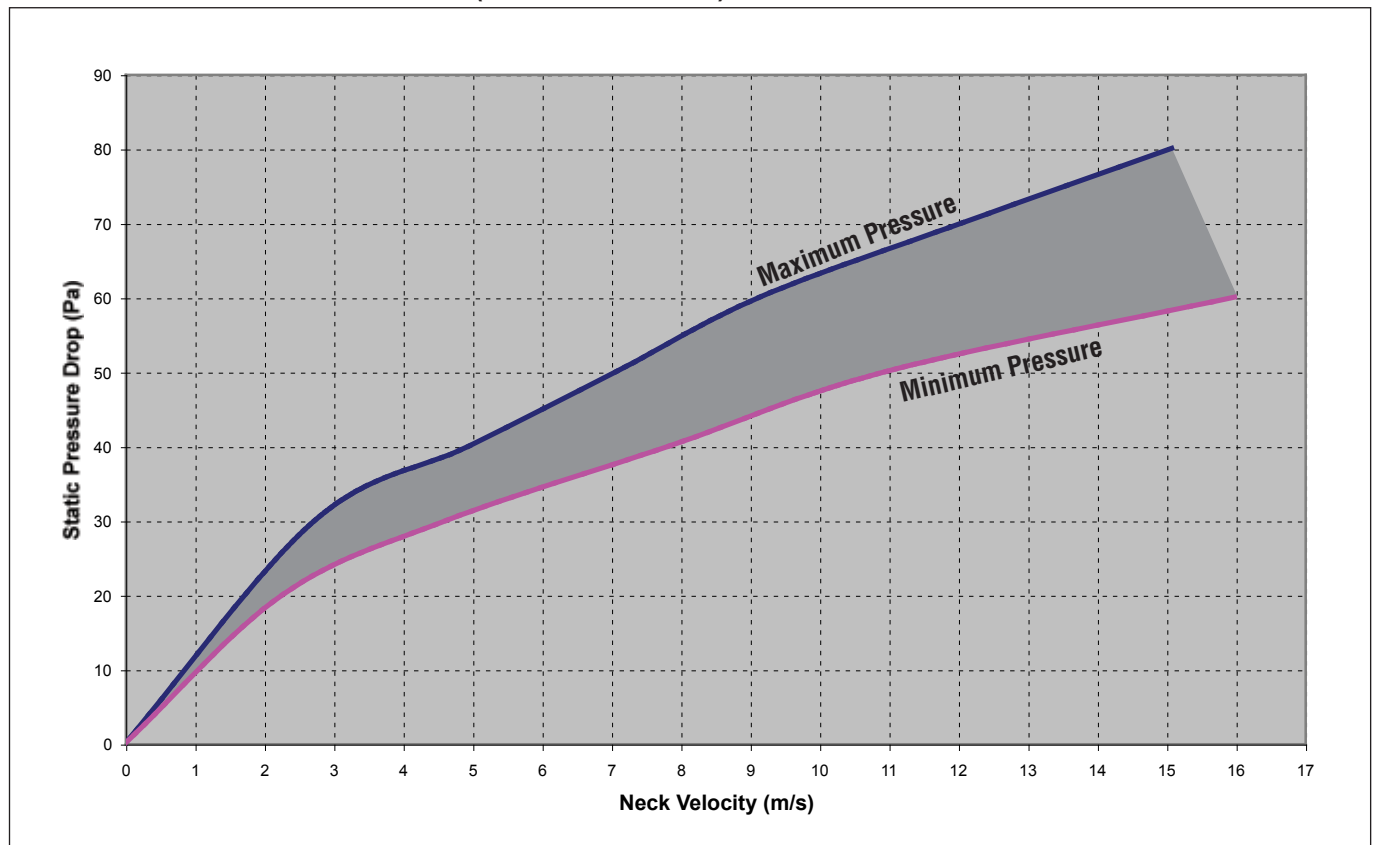

■ SPRD Suggested Specification

The pressure relief damper shall be ASLI, model SPRD. Damper shall be single blade design with counter weight located behind the blade. Damper frame shall be galvanized steel 0.7mm thickness. Damper blade shall be galvanized steel 0.7mm thickness. The counter weight shall be adjustable by moving up or down along the steel rod to control the inlet pressure. The counter weight shall be able to be locked in its position on the steel rod by using simple tools. The damper shall be epoxy coated and furnished to architectural requirement.

■ SPRD Order Code Unit:mm

Model	Neck Size (W X H)
SPRD	250mm X 250mm

Example: SPRD-N250mm x 250mm