

KD-TC Non Return Damper

■ Description

ASLI non return damper (KD-TC) is designed for automatic shut off of individual section of air conditioning system. Contemporary styling features blades that overlap the frame for optimum leakage proof. The counterbalance arm provides the flexibility to increase or reduce the pressure drop across the damper; hence KD-TC can serve as a pressure relief damper as well. The damper's aesthetical appearance is maintained by sturdy, corrosion resistant aluminum and galvanized steel construction. Two models available, KD-TC1 and KD-TC2 for heavy duty usage.

■ Materials

KD-TC1

- Frame : Galvanized steel , 1.0mm thickness.
- Blade :Galvanized sheet , 0.7mm thickness.

KD-TC2

- Frame : Galvanized steel , 1.5mm thickness.
- Blade :Galvanized sheet , 1.2mm thickness.

■ Surface Finish

- Frame: Mill galvanized.
- Blade : Mill galvanized.

■ Blade Action

- Parallel blade.

■ Bearing

- Engineering plastic sleeve as standard. Bronze bush is optional.

■ Blade Dimension Limit

- Maximum Blade Length = 1000mm
- Maximum Blade Width = 170mm

■ Temperature Limits

- -40°C to +93°C

■ Flanged

- Slip joint or TDC Joint.

■ Physical Dimension (mm)

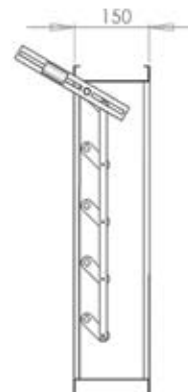
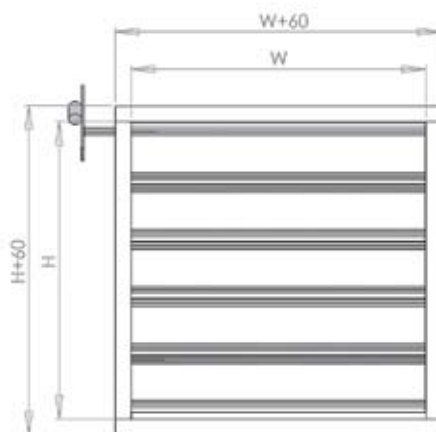
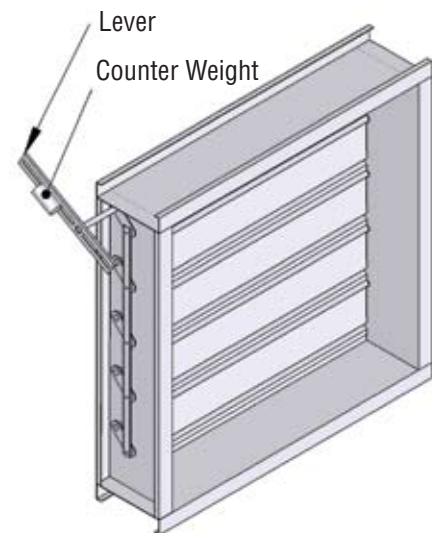

KD-TC Non Return Damper

■ KD-TC Counterbalance Arm And Weight Adjustment

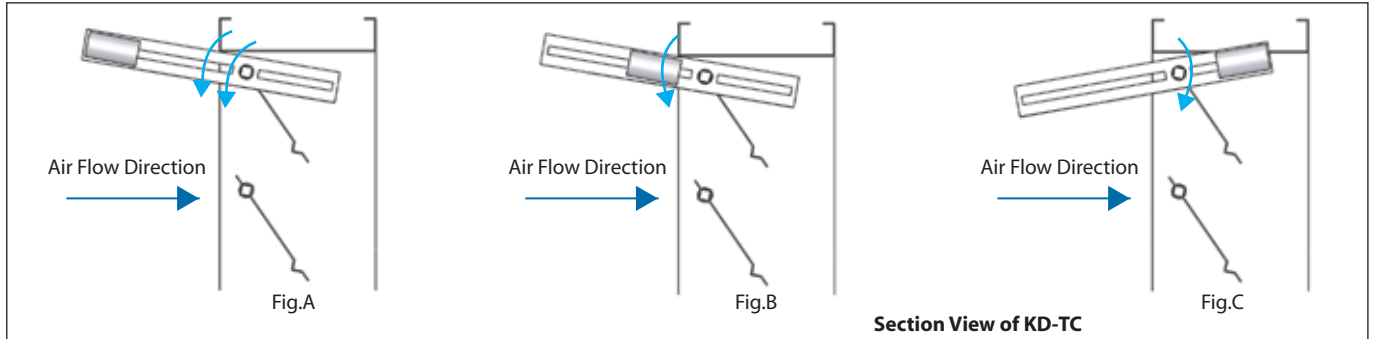

Heavy duty non return damper for high air velocity without counterweight often create substantial pressure drop due to its heavy gauge damper blade. ASLI KD-TC is designed for high air velocity with minimum pressure drop. The user can adjust the location of the weight to counterbalance the weight of the damper blades, hence the pressure required to open the blades will be reduced greatly. Location of weight as shown in Fig. A will create stronger torque on the pivot point compare to Fig. B, therefore the pressure required to open the damper blades for Fig. A is less than Fig. B. The user can adjust the weight location anywhere on the counterbalance arm to the preferred pressure drop.

ASLI KD-TC can also be used as a pressure relief damper. If the required pressure is low, the user can adjust the weight location to the required pressure as shown in Fig. A and Fig. B. If the required pressure is high, the user can adjust the counterbalance arm and weight location as shown in Fig. C, the weight will increase the resistance to the air flow.

Recommended Installation

1. KD-TC should be located at least one-half the fan diameter away from the fan when used in fan discharge applications.
2. KD-TC has to be installed with blade running horizontally.
3. For proper operation, damper must be installed square and free from racking.
4. KD-TC is intended to be self-supporting only in the largest single section size. Bracing is required in multiple section damper assemblies to support the weight of the assembly and to hold against system pressure. It is recommended that appropriate bracing to support damper horizontally at least once for every 8 feet of damper width. More bracing may be required for vertical assemblies and higher system pressure.

■ Performance Data Model: KD-TC1

Damper Width (inch)	Maximum Back Pressure (inch w.g.)	Maximum System Velocity (fpm)	Leakage	
			CFM /ft ²	% in Max. Air Flow
48	2.0	1500	28	1.9
36	3.0	1500	28	1.9
24	4.0	1500	35	2.3
12	5.0	1500	45	3.0

• Leakage information based on differential pressure 1.0 inch w.g.

■ Performance Data Model: KD-TC1

Damper Width (inch)	Maximum Back Pressure (inch w.g.)	Maximum System Velocity (fpm)	Leakage	
			CFM /ft ²	% in Max. Air Flow
48	4.0	3000	28	0.9
36	6.0	3000	28	0.9
24	8.0	3000	35	1.2
12	10.0	3000	45	1.5

• Leakage information based on differential pressure 1.0 inch w.g.

■ KD-TC Order Code Unit:mm

Model	Neck Size (W X H X D)	Flanged
KD-TC1, KD-TC2	600mm X 600mm X 150mm	TDC Joint

Example: KD-TC1 – 600mm X 600mm X 150mm – TDC Joint