

SD-T Smoke Damper Tested and conform to UL555S

Description

ASLI SD-T smoke dampers are low leakage damper constructed with triple V-groove blades designed to be used in ducts that penetrate smoke rated barriers. The SD-T may be installed vertically or horizontally of a smoke barrier and is designed for use in systems with airflow in either direction with velocity up to 2000fpm and pressure up to 4" w.g.

Materials

- Frame: Galvanized steel, 1.5mm thickness.
- Blade: Galvanized steel, 1.5mm thickness.
- Blade Seal: Silicone strip (Fire resistance up to 250°C).
- Jamb Seal: Reinforced stainless steel plate, compression type.
- Bearing: Bronze bush pressed into frame.
- Axles: Square steel bar shaft.

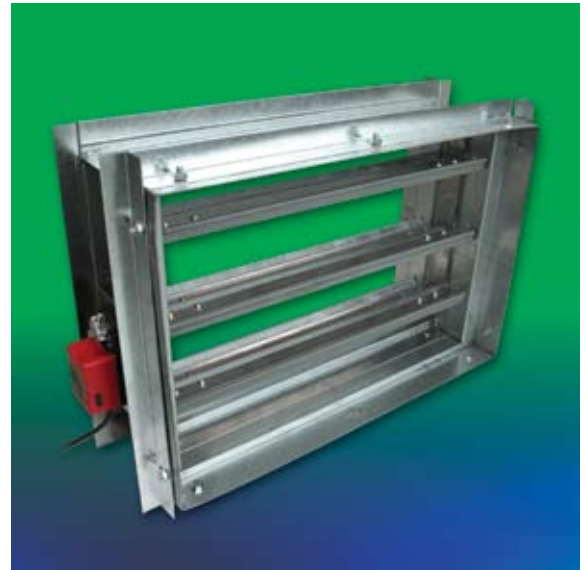

Surface Finish

- Mill galvanized

Blade Action

- Parallel blade

Blade Dimension Limits

- Maximum blade length = 1000mm
- Maximum blade width = 160mm

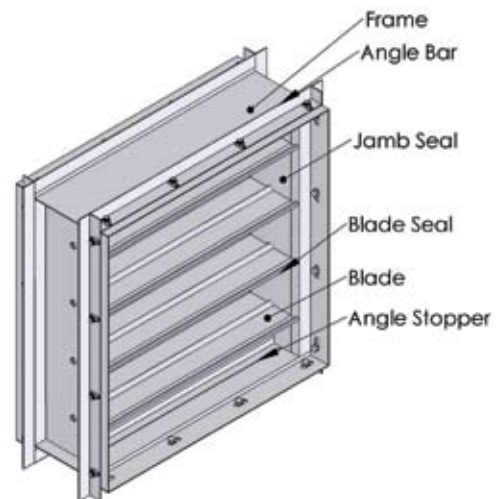

SD-T Construction Illustrations

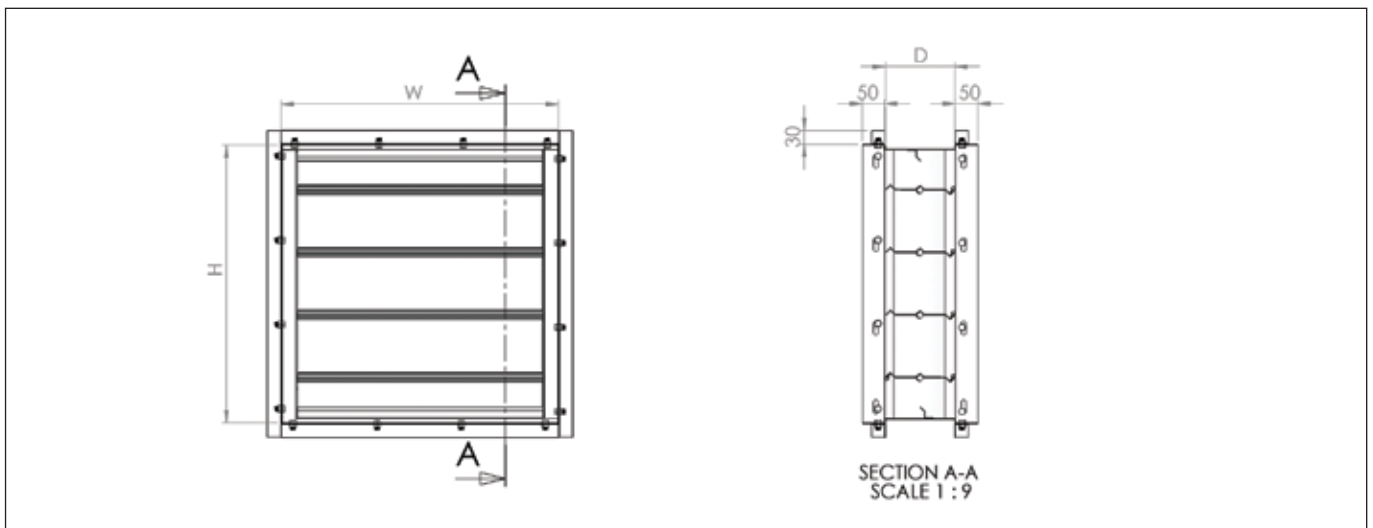

SD-T Smoke Damper Tested and conform to UL555S

SD-T Features

- Tested in accordance to UL555S. Leakage rating Class 3.
- Blade edge seal of silicone strips seal up the gap between the blades and stoppers when the damper is fully close.
- Jamb seal of reinforced stainless steel plates seal up the gap between the blades and side frame when the damper is fully close.
- Blade edge seal of silicone strips could withstand temperature up to 250°C.
- Angled stopper with single longitudinal grooves for better seal purpose.
- Low air/smoke leakage even in high static pressure.
- Rigid 'triple-vee' blade design
- Linkages are concealed in the frame to prevent malfunctioning caused by improper installation.
- Vertical (wall) or horizontal (ceiling) installation.
- Closed by means of damper actuator.
- Blades must be installed horizontally.

Comparison of conventional damper and SD-T smoke damper

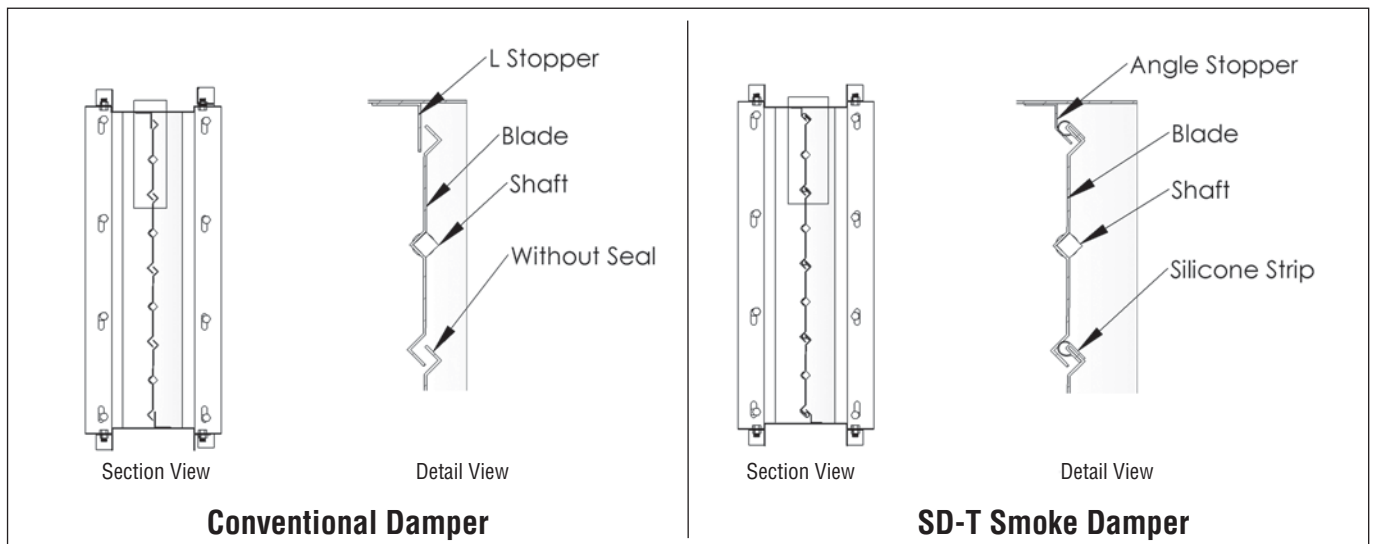

When the dampers are fully closed, there are still some visible gaps between the blades and the stoppers in conventional damper. SD-T incorporated blade seal and angle stopper to seal up the gaps. SD-T has also improved on its jamb seal by using reinforced stainless steel plate, which will not deform or vibrate in high pressure or when the blades are rotating. Hence the air leakage rate has been greatly reduced.

SD-T Performance Data

To determine pressure drop

1. Select the damper free area (ft²) based on width (W) and height (H) from the table below.
 2. Given the air velocity and damper size, substitute the free area (ft²) into the formula below and get the pressure drop value.
- Please take note on the unit of parameters.

Height H (mm)	Width, W (mm)										
	200	300	400	500	600	700	800	900	1000	1100	1200
200	0.20	0.34	0.47	0.61	0.74	0.87	1.01	1.14	1.28	1.41	1.55
300	0.34	0.57	0.79	1.02	1.24	1.47	1.70	1.92	2.15	2.37	2.60
400	0.50	0.83	1.17	1.50	1.84	2.17	2.50	2.84	3.17	3.50	3.84
500	0.64	1.06	1.49	1.91	2.34	2.76	3.19	3.61	4.04	4.46	4.69
600	0.78	1.29	1.81	2.33	2.84	3.36	3.88	4.39	4.91	5.43	5.94
700	0.94	1.25	1.56	1.87	2.19	2.50	2.81	3.12	3.43	3.75	4.06
800	1.07	1.79	2.51	3.22	3.94	4.65	5.37	6.08	6.80	7.52	8.23
900	1.24	2.06	2.88	3.71	4.53	5.35	6.18	7.00	7.82	8.65	9.47
1000	1.37	2.29	3.20	4.12	5.03	5.95	6.86	7.78	8.69	9.61	10.52
1100	1.23	2.25	3.27	4.29	5.32	6.34	7.36	8.39	9.41	10.43	11.45
1200	1.34	2.45	3.57	4.68	5.79	6.91	8.02	9.14	10.25	11.36	12.48

SD-T Smoke Damper Tested and conform to UL555S

$$P = 2.75 \left[\frac{Q - V}{\text{Free Area} \times 4005} \right]^2$$

P = Pressure drop (inch w.g.)
 V = Duct Air velocity (fpm)
 Q = Air flow rate (CFM) = Duct Area (ft²) X Duct Air Velocity (fpm)

* All data has been corrected to represent standard air at a density of 0.075 lb/ft³.
 * All data has been generated in which the damper blades are fully open.

Example:

Given: Duct Air Velocity = 1000fpm
 Duct Size = Damper Size = 500mm (W) X 500mm (H)
 Duct Area = 2.69 ft²
 Find: Pressure Drop

Q = Duct Area (ft²) X Duct Air Velocity (fpm)
 = 2.69 X 1000
 = 2690 CFM

Refer to the table above, free area for damper size 500mm(W) X 500mm (H) = 1.91 ft²

$$P = 2.75 \left[\frac{2690 - 1000}{1.91 \times 4005} \right]^2$$

P = 0.0286inch w.g.
 P = 7.12 Pa

SD-T Leakage Test

The samples in the table below were subjected to the leakage test at static pressure of 4" w.g. as specified in the UL555S

Size (inch) W X H	Flow Direction	Leakage @Ambient (CFM/ft ²)	Leakage @250°F (CFM/ft ²)
8 X 48	Downstream	29.5	-
8 X 48	Upstream	24.4	-
36 X 10	Downstream	22.3	-
36 X 10	Upstream	41.5	-
36 X 48	Downstream	14.1	-
36 X 48	Upstream	31.3	-
36 X 48	Downstream	-	16.1
36 X 48	Upstream	-	39.3
36 X 24	Downstream	-	10.9
36 X 24	Upstream	-	7.5

Based on the result of leakage tests, model SD-T dampers are eligible for a leakage rating of Class III.

SD-T Suggested Specification

The smoke dampers shall be ASLI, model SD-T. Damper frame shall be galvanized steel 1.5mm thickness. Damper blades shall be single skin galvanized steel, 1.5mm thickness with three longitudinal grooves for reinforcement. The blade stopper on damper frame shall be galvanized steel, 1.5mm thickness with single longitudinal grooves for better seal purpose. Bearing shall be bronze bush pressed into frame. Jamb seals shall be reinforced stainless steel compression type. Blade edge seals shall be inflatable silicone strip. Dampers and actuators shall be supplied as a single entity. Dampers shall be classified as Smoke Dampers in accordance with the latest version of UL555S. The leakage rating in accordance with UL555S shall be Leakage Class 3.

SD-T Order Code Unit:mm

Model	Neck Size (W X H X D)	Connection Method (Left)	Connection Method (Right)
SD-T	1000mm X 1000mm X 150mm	Angle bar (A) Slip Joint (S) Flat Joint (F) Flange for TDC (T)	Angle bar (A) Slip Joint (S) Flat Joint (F) Flange for TDC (T)

Example: SD-T 1000mmX1000mmX150mm-AA