

## FSD60/MFSD60 Multi-blade Fire Damper

Tested and conformed to BS 476 part 20: 1987 standard  
(Fire Resistance Test - 4 hours)

### Description

The ASLI multi-blade fire dampers have been developed to provide the versatility required for today's complex and sophisticated fire protection and safety building system. There are two types of fire dampers: Fire damper with fusible link (FSD60) and motorized fire damper (MFSD60).

### Materials

- Frame: Galvanized steel, 1.5mm thickness.
- Blade : Galvanized steel, 1.5mm thickness.
- Jamb seal: Stainless steel plate, compression type.
- Blade seal: Silicone strip. (Optional)

### Surface Finish

- Mill galvanized.

### Blade Actions

- FSD60: Parallel blade.
- MFSD60: Parallel blade.

### Axles

- 10mmX10mm square bar plated steel.

### Bearing

- Bronze bush pressed into frame.

### Blade Dimension Limits

- Maximum blade length = 1000mm
- Maximum blade width = 160mm

### Fire Damper (FSD60)

During fire, the FSD60 provides a quick closure response by means of tensioned spiral spring mounted at the side when the fusible link fuses at 74°C (165°F).

### Motorized Fire Damper (MFSD60)

During fire, a signal will be sent from sensor or control unit to the actuator of MFSD60. Upon receiving the signal, MFSD60 will be closed by means of actuator.

**MFSD60-1T:** Actuator mounted exposed at the side of the fire damper.

**MFSD60-2T:** Actuator mounted in a compartment at the corner of the fire damper.

**MFSD60-3T:** Actuator mounted in a compartment at the side of the fire damper.

**MFSD60-4T:** Actuator mounted in an extrusion fitting.

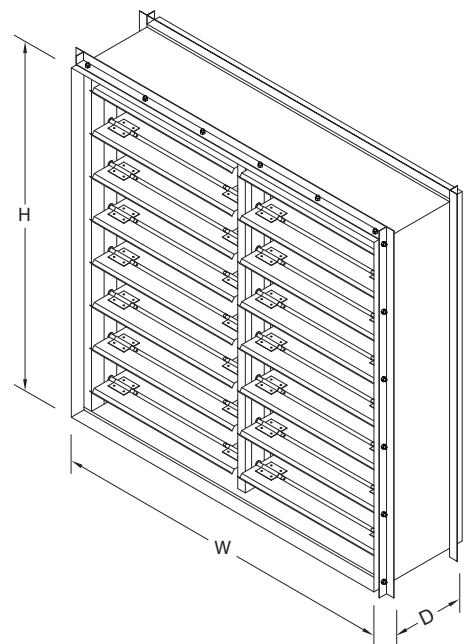

## FSD60/MFSD60 Multi-blade Fire Damper

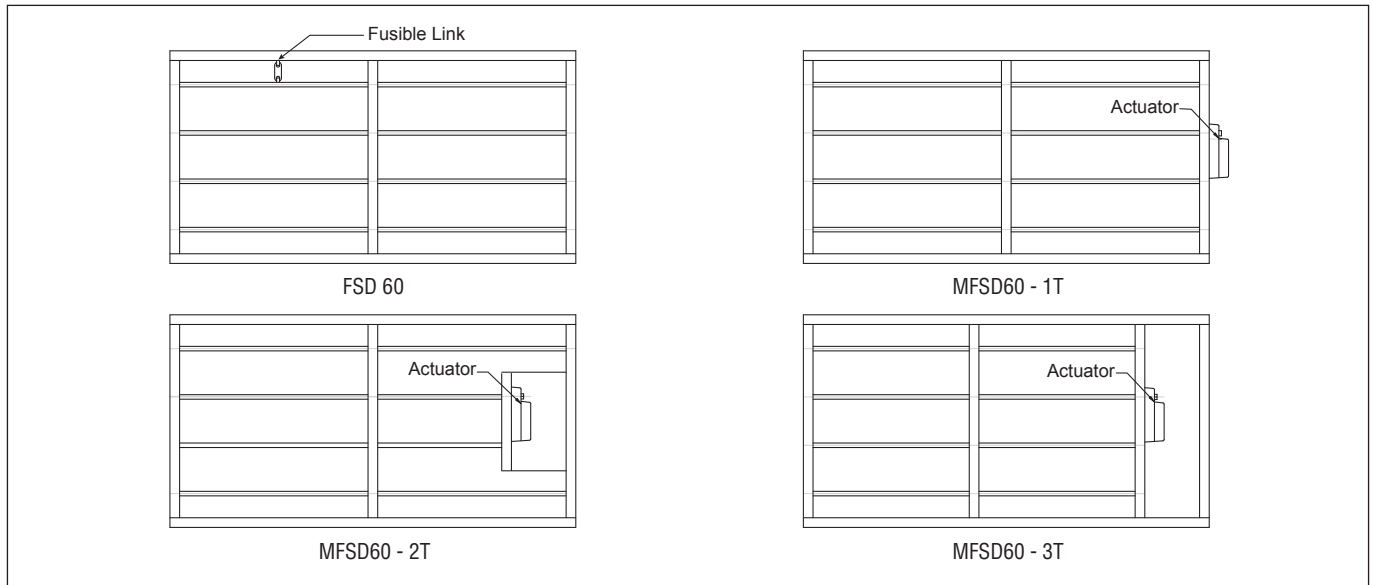

### ■ FSD60/MFSD60 Features

- Quick closure response (FSD60).
- Stainless steel side seal at each side of the frame.
- Rigid 'triple-vee' blade design.
- Easy to install.
- Fire damper can be installed in the wall (vertically) or on the ceiling (horizontally).
- Fire damper can be installed with the blade running horizontally or vertically.
- Linkages are concealed in the frame to prevent malfunctioning caused by improper installation.
- **FSD60 is tested and conformed to BS 476 part 20: 1987 standard (Fire Resistance Test - 4 hours)**

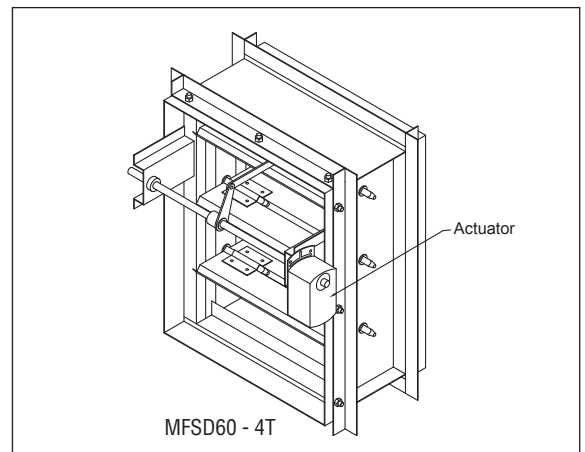

### ■ Recommended Fire Damper Installation

A: 6" (152mm) on each side for dampers intended for use without an actuator or a factory installed access door.

A: 6" (152mm) on one side and 16" (304mm) on the opposite side for damper intended for use with an actuator and/or a factory access door, on the longer side.

A: 16" (304mm) on each side for damper intended for use with an actuator on one side and a factory installed access door on the other side.

Note: Installation details above are based on SMACNA Damper Installation Guide as reference.

## FSD60/MFSD60 Multi-blade Fire Damper

### ■ Connection Method

- Angle bar (A) as standard.
- Flange joint for TDC (T), Flat joint (F), L Joint (L) as optional.
- Flange connection can be a combination of A,T,F,L; for example: LA indicates one side L Joint (L) and the other side Angle Bar (A) connection.
- Dimension shown on the following drawings can be adjusted.

### ■ Construction Illustration of Flange Connections

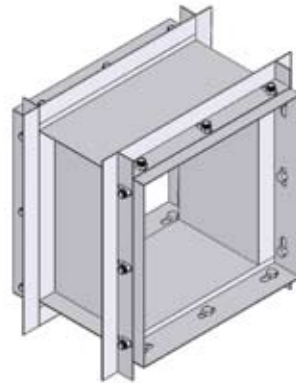
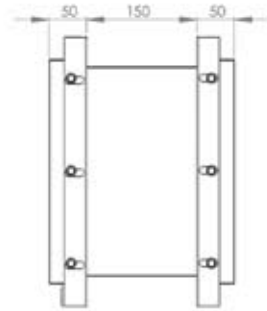

Angle bar (A) connection as standard for wall and ductwork installation

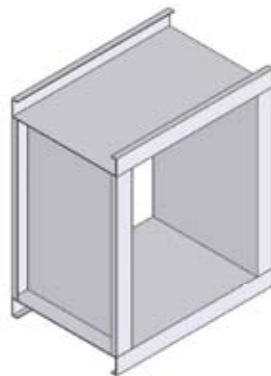

Flange joint for TDC (T) connection (optional) for ductwork installation

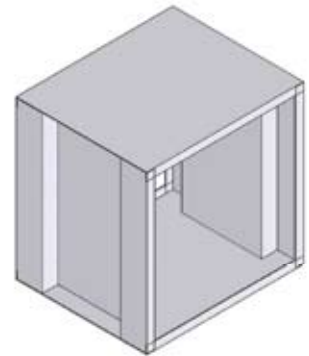
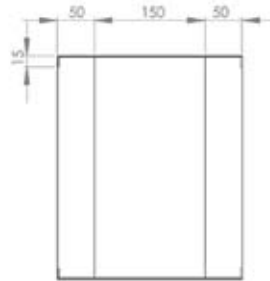

Flat joint (F) connection (optional) for wall/ductwork installation slot-in type

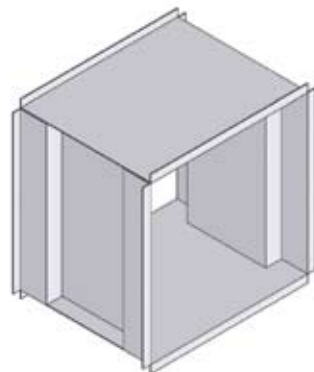
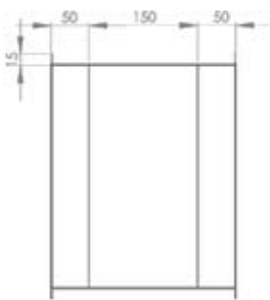

L joint (L) connection (optional) to be coupled with louvers

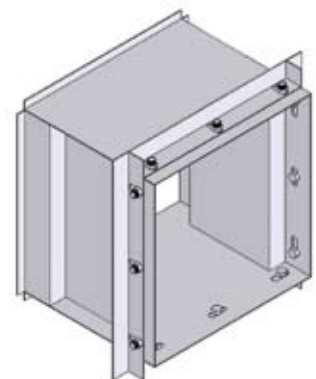
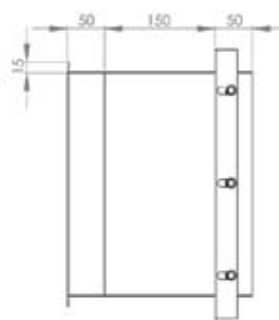

L joint and angle bar (LA) connection (optional) to be coupled with louver and joined to ductwork on the other side

## FSD60/MFSD60 Multi-blade Fire Damper

### ■ FSD60/MFSD60 Performance Data

Damper Width (inch)	Maximum System Pressure (inch w.g.)	Maximum System Velocity (fpm)	Leakage	
			CFM /ft <sup>2</sup>	% in Max. Air Flow
48	4.0	2000	35	1.8
36	4.0	2000	35	1.8
24	4.0	2000	45	2.3
12	4.0	2000	55	2.8

To determine pressure drop

1. Select the damper free area (ft<sup>2</sup>) based on width (W) and height (H) from the table below.
2. Given the air velocity and damper size, substitute the free area (ft<sup>2</sup>) into the formula below and get the pressure drop value.

Please take note on the unit of parameters.

Height H (mm)	Width, W (mm)										
	200	300	400	500	600	700	800	900	1000	1100	1200
200	0.20	0.34	0.47	0.61	0.74	0.87	1.01	1.14	1.28	1.41	1.55
300	0.34	0.57	0.79	1.02	1.24	1.47	1.70	1.92	2.15	2.37	2.60
400	0.50	0.83	1.17	1.50	1.84	2.17	2.50	2.84	3.17	3.50	3.84
500	0.64	1.06	1.49	1.91	2.34	2.76	3.19	3.61	4.04	4.46	4.69
600	0.78	1.29	1.81	2.33	2.84	3.36	3.88	4.39	4.91	5.43	5.94
700	0.94	1.56	2.19	2.81	3.43	4.06	4.68	5.31	5.93	6.56	7.18
800	1.07	1.79	2.51	3.22	3.94	4.65	5.37	6.08	6.80	7.52	8.23
900	1.24	2.06	2.88	3.71	4.53	5.35	6.18	7.00	7.82	8.65	9.47
1000	1.37	2.29	3.20	4.12	5.03	5.95	6.86	7.78	8.69	9.61	10.52
1100	1.23	2.25	3.27	4.29	5.32	6.34	7.36	8.39	9.41	10.43	11.45
1200	1.34	2.45	3.57	4.68	5.79	6.91	8.02	9.14	10.25	11.36	12.48

$$\Delta P = 2.75 \left( \frac{Q}{\text{Free Area}} - V \right)^2 \frac{1}{4005}$$

ΔP = Pressure drop (inch w.g.)

V = Duct Air velocity (fpm)

Q = Air flow rate (CFM) = Duct Area (ft<sup>2</sup>) X Duct Air Velocity (fpm)

\* All data has been corrected to represent standard air at a density of 0.075 lb/ft<sup>3</sup>.

\* All data has been generated in which the damper blades are fully open.

Example:

Given: Duct Air Velocity = 1000fpm

Duct Size = Damper Size = 500mm (W) X 500mm (H)

Duct Area = 2.69 ft<sup>2</sup>

Find: Pressure Drop

Q = Duct Area (ft<sup>2</sup>) X Duct Air Velocity (fpm)

= 2.69 X 1000

= 2690 CFM

Refer to the table above, free area for damper size 500mm(W) X 500mm (H) = 1.91 ft<sup>2</sup>

$$\Delta P = 2.75 \left( \frac{2690}{1.91} - 1000 \right)^2 \frac{1}{4005}$$

ΔP = 0.0286inch w.g.

ΔP = 7.12 Pa

### ■ FSD60/MFSD60 Order Code Unit:mm

Model	Neck Size (W X H X D)	Connection Method (Left)	Connection Method (Right)
FSD 60 MFSD 60	1000mm X 1000mm X 150mm	Angle bar (A) Slip Joint (S) Flat Joint (F) Flange Joint for TDC (T)	Angle bar (A) Slip Joint (S) Flat Joint (F) Flange Joint for TDC (T)

Example: FSD60-1000mmX1000mmX150mm-AA