

G1- Opposed Blade Damper

Materials

- G1-T Frame 0.6mm SPGC galvanized steel. Blade 0.5mm SPGC galvanized steel.

Surface Finish

- G1-T Matt black as standard.
- Maximum dimension is 500mm x 500mm. Damper size bigger than this will come in sections.
- Gear operated, can be set at fully open, half open & fully close.

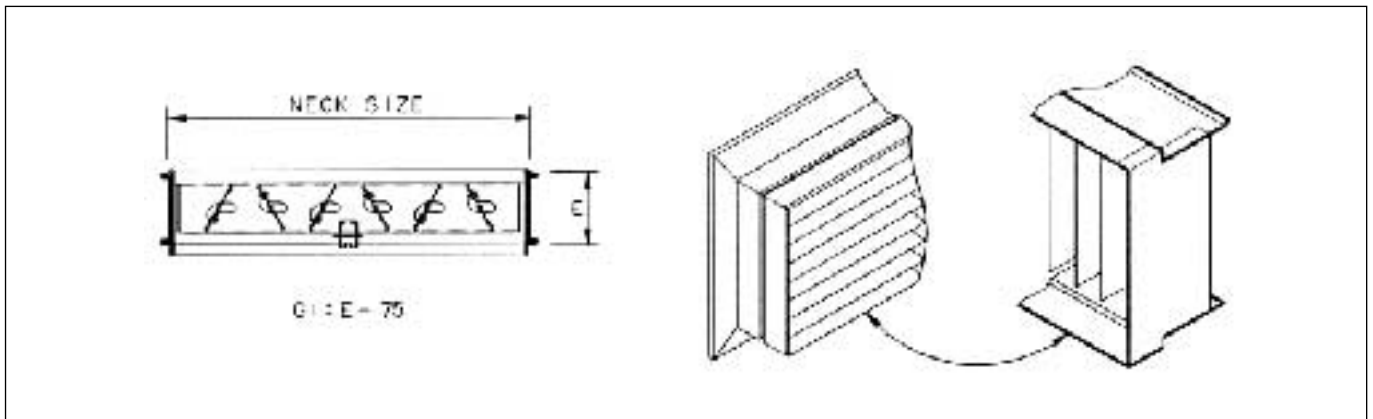
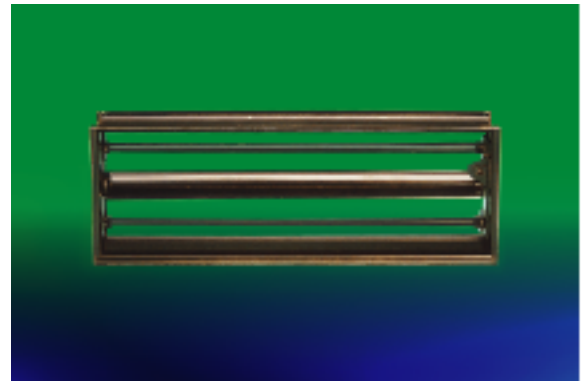

G2 Volume Extractor

Materials

- G2-T 1.0mm SPGC galvanized steel.
- G2-S 0.5mm stainless steel SUS. 304.

Surface Finish

- G2-T Matt black as standard.
- G2-S Stainless steel original colour.
- Maximum dimension is 800mm x 500mm.
- Suitable for model GV & GH wall grille as guide vanes.
- Maximum angle of opening 35° - 40°.

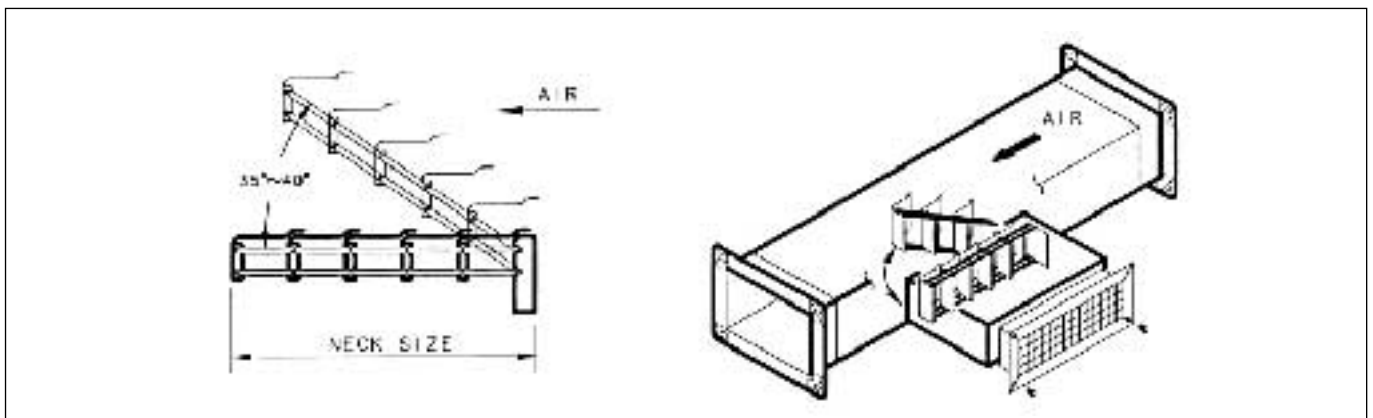
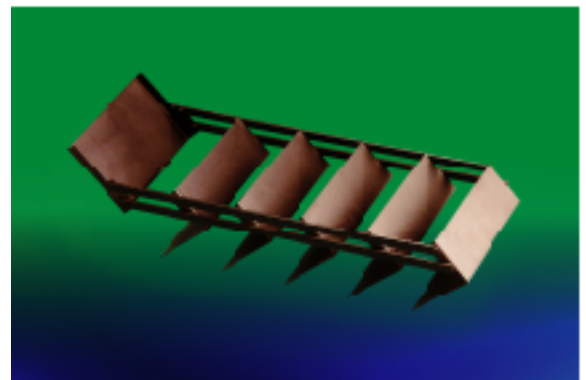

Recommended Noise Criteria for Rooms (3)

Type of Area	Range of NC Criteria Curves	Type of Area	Range of NC Criteria Curves
RESIDENCES Private homes (rural and suburban) Private homes (urban) Apartment houses, 2-and 3-family units	20-30 25-35 30-40	CHURCHES AND SCHOOLS Sanctuaries Libraries Schools and classrooms Laboratories Recreation halls Corridors and halls Kitchens	20-30 30-40 30-40 35-45 35-50 35-50 40-50
HOTELS Individual rooms or suites Ballrooms, banquet rooms Halls and corridors, lobbies Garages Kitchens and laundries	30-40 30-40 35-45 40-50 40-50	PUBLIC BUILDINGS Public libraries, museums, court rooms Post office, general banking areas, lobbies Washrooms and toilets	30-40 35-45 40-50
HOSPITALS AND CLINICS Private rooms Operating rooms, wards Laboratories, halls and corridors Lobbies and waiting rooms Washrooms and toilets	25-35 30-40 35-45 40-50	RESTAURANTS, CAFETERIAS, LOUNGES Restaurants Cocktail lounges Night clubs Cafeterias	35-45 35-50 35-45 40-50
OFFICES Board room Conference rooms Executive office Supervisor office, reception room General open offices, drafting rooms Halls and corridors Tabulation and computation	20-30 25-35 30-40 30-45 35-45 35-50 40-60 40-50	STORES, RETAIL Clothing stores Department stores (upper floors) Department stores (main floor) Small retail stores Supermarkets	35-45 40-50 40-50
AUDITORIUMS AND MUSIC HALLS Concert and opera halls Studios for sound reproduction Legitimate theaters, multi-purpose halls Movie theaters, TV audience studios Semi-outdoor amphitheaters Lecture halls, planetarium Lobbies	15-25 25-30 30-35 35-45	SPORTS ACTIVITIES, INDOOR Coliseums Bowling alleys, gymnasiums Swimming pools	30-40 35-45 35-45
		TRANSPORTATION (RAIL, BUS, PLANE) Ticket sales offices Lounges and waiting rooms	30-40 35-50